

Handsteuerventile Typ P 80

Technische Daten

Durchfluss max 80 L/min.

Betriebsdruck max 300 bar

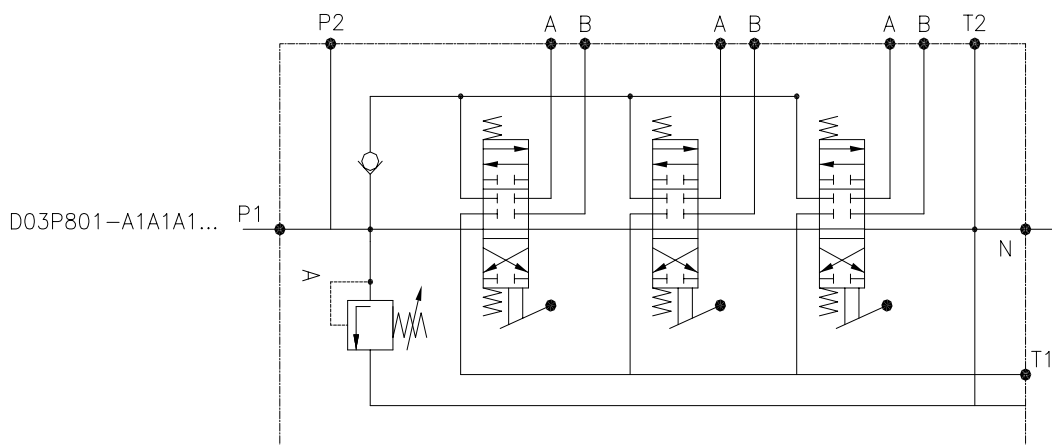
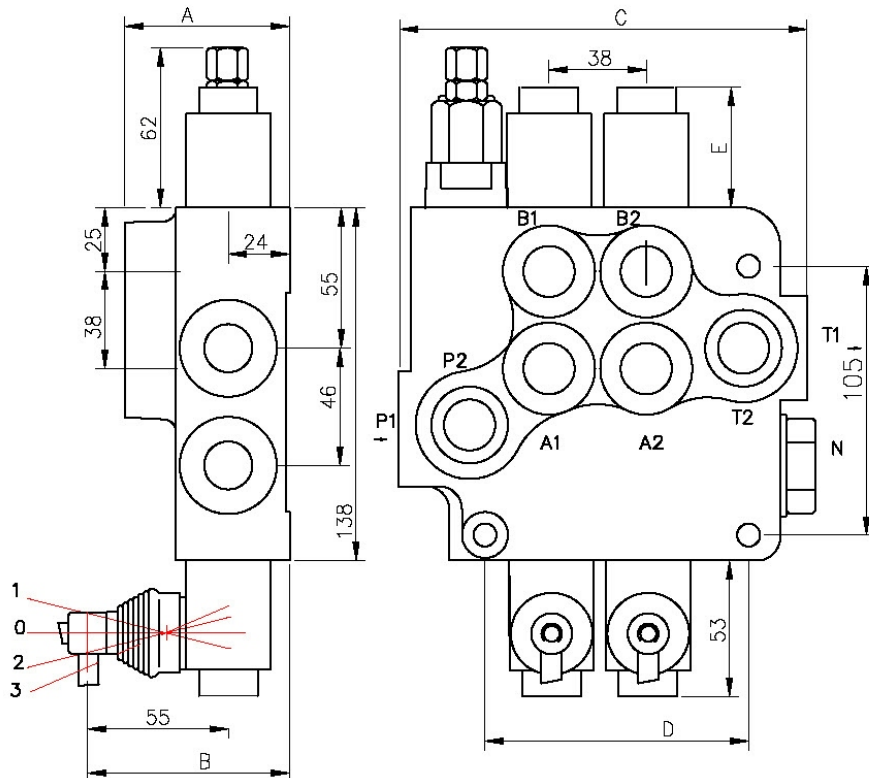

Artikel	Bezeichnung	T-N	A-B-P	L/min	Hebel	A	B	C	D
230155	P80/1-A1	G 3/4"	G 1/2"	70	1	65	79	107	65
230156	P80/1-A1x2	G 3/4"	G 1/2"	70	2	80	94	160	103
230157	P80/1-A1x3	G 3/4"	G 1/2"	70	3	80	94	198	141
230158	P80/1-A1x4	G 3/4"	G 1/2"	70	4	80	94	242	179
230159	P80/1-A1x5	G 3/4"	G 1/2"	70	5	80	94	280	217
230160	P80/1-Ax6	G 3/4"	G 1/2"	70	6	80	94	318	255

Weitere Möglichkeiten auf Anfrage

Kolben Typ

A	
B	
C	
D	
E	
F	
G	
H	
M	
N	
O	
P	
Q	
R	
S	
T	

Rastierungen

code	spool control
1	
2	
3	
4	
5	
6	
7	
8	
9	
10	
11	
12	
13	

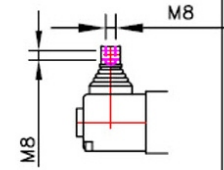
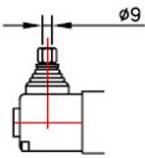
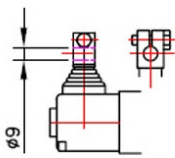
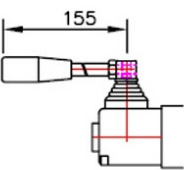
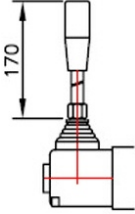
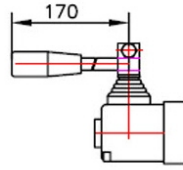
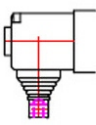
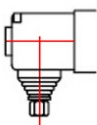
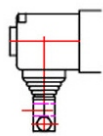
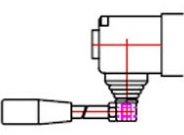
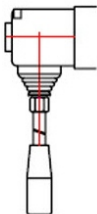
KZ		KY		KI	
KZ1		KY1		KI1	
KZ0		KY0		KI0	
KZ01		KY01		KI01	